

NDV1200/1600/1800/2500/2600

LAHMEYER-Compact-Substation[®]

type NDV1200 ,NDV1600 ,NDV1800 ,NDV2500 ,NDV2600



SÄCHSISCH-BAYERISCHE
STARKSTROM-GERÄTEBAU GMBH
Ohmstraße 1 • 08496 Neumark/Sachsen
Telefon: +49 (0) 3 76 00 / 83-0
Tefefax: +49 (0) 3 76 00 / 34 14
E-Mail: sgb@sgb-neumark.de
www.sgb-trafo.de

NDV 1600 / 1800 / 2500 / 2600 05/2008 Meuleman
page - 1 - of 10

subject to technical changes !

NDV1200/1600/1800/2500/2600

**General information about the delivery of a complete manufactured
substation type NDV1200/1600/1800/2500/2600
according to IEC EN VDE 62271 - 202**

list of contents:

1. Application and use
2. Conditions of use
3. Basic data of station (depending on specification)
4. Housing construction
material and surface treatment
5. Equipment possibilities
 - MV-switchgear
 - Transformer
 - LV-compartment
6. Earthing appliance
7. Transport, placing and mounting
8. Dimensions and weights
 - NDV 1200
 - NDV 1600
 - NDV 1800
 - NDV 2500
 - NDV 2600

Drawings:

- excavation plan
- lifting plan
- transport plan
- modular base unit, patented
- test sheet Field strength measurement

Internal arcing test

NDV1200/1600/1800/2500/2600

1. Application and use

The factory assembled compact substations type NDV1200/1600/1800 and NDV2500/2600 can be used for the MV-power supply of industry, branches and other bigger building complexes. These stations are very interesting for the decentralized power supply. Wind-power generators are in the position to supply power of up to 2500 kVA via our factory assembled compact substations direct into the electric supply network.

2. Conditions of use

The compact substation type NDV 1200 up to NDV 2600 are stand-alone constructions with small dimensions. Erection and dimensions are so provided, that set up, operation and maintenance are without problems possible even on public sidewalks and industry areas. All operations can be done by opened doors in front of the station. The stations can also be used in areas with complicated environmental conditions, such as

- industry areas
- moist, sandy or dusty areas

The technical lifetime of the basic construction is at least 40 years.

3. Basic data of station (depending on specification) :

- ambient temperature: – 30 up to + 50 °C
- operational altitude: up to 1000m (higher altitude possible after technical modification of used equipment)
- rated voltages: 12kV, 24kV und 36kV
- rated power: up to and including 1600 kVA as NDV 1600 with oil insulated transformer
up to and including 2500 kVA as NDV 2500 with oil insulated transformer
up to and including 800 kVA with cast resin transformer
- frequencies: 50 Hz and 60 Hz, also special frequency 16 2/3 Hz on request.
- rated withstand voltage: 28/75 kV , 50/125 kV and 70/195 kV
- rated short-time current: 16 kA 1 sec

NDV1200/1600/1800/2500/2600

- rated peak current: 50 kA
- star point treatment: fixed – or low resistance
- type of used components: air insulated and SF6 insulated switchgears (12kV, 24kV, 36kV)
oil filled insulated transformers up to 2500 kVA and up to 36 kV
cast resin transformers up to 800 kVA and up to 24 kV
- enclosure type: 20K (up to 1600 kVA)
- protection class MV- / LV-room: IP 54D
- protection class transformer room: IP 43D stoke safe
- erection: generally 500 - 550 mm in the ground
- operation: from outside; walk in not possible
- roof load: 2500 N/m (during installation or snow)
- wind force acc. IEC 60694 (700N/m²)
- outer forces by impact stress on enclosure, doors, rock lever handles and ventilation openings acc. to IEC 1330 Annex C.
- noise level: reduction of transformer, noise level within station by 3 dB (A).
- EMV-test: on all test points with 200 mm distance to the station levels always below < 100 μT.
- fire protection class: equivalent F90
- short circuit strength: Internal arcing test with IAC B 16kA, 1 S. according IEC EN VDE 62271-202
The validity of the results of the test IAC AB 20kA 1S, we have made with the Substation NDV400 are extended to the substation NDV1200 up to 2600.
The constructive design is similar as mentioned in IEC EN VDE 62271 – 202.

NDV1200/1600/1800/2500/2600

4. Housing construction

The compact substations type NDV 1200 up to NDV 2600 are, as all other Lahmeyer-compact-substations[®], factory assembled and type tested units.

They do have a MV-, transformer- and LV-room.

After connection of the MV- and LV-cables the substation is ready for operation.

The housing is manufactured as metal-sheet bended constructions and consists of:

- base frame including oil collecting pan, constructed as modular base unit.
The oil collecting pan is made out of 4 mm thick steel sheet, oil-tight welded, hot dip galvanized and from the outside powder coated. It is kept between 2 sidewalls, made out of galvanized steel-plate, powder coated. There is no contact between the oil collecting pan and the surrounding ground.
Below the oil collecting pan are mounted wide and stiff constructed carriers. They are used for supporting, lifting and bedding the complete station.
- housing, incl. doors and cover sheets for the MV- and LV-rooms as one unit removable from the base foundation.
- carriers to keep the MV- and LV-equipment, connected to the steel base foundation.
- a simple removable roof (4 fixing screws must be unscrewed in the transformer compartment).
- plug-in-shutters as entry to the transformer room, located in the side walls

Material and surface treatment

Material (in the ground)	1) side wall construction out of galvanized steel-plate, 3 mm thick, with an 100 % poreless double - powder coating of 2x70 μ ; colour: RAL 7032 – S (structure); 2) oil collecting pan to keep the transformer out of 4 mm thick steel, hot dip galvanized (> 750 gr/m ² = >70 μ) and powder coated (70 μ) ; RAL 7032 - S
Material (above the ground)	steel sheet, 2 mm, strip galvanized (> 225 gr/ m ²) und 100 % poreless powder coated, thickness of coating > 70 μ . The used coating powders are free of heavy metal and non toxic. Galvanisation plus powder coating = highest corrosion protection. Standard colour: Light grey (RAL 7032- S).

Remark: The standard powder coat can be substituted by another colour by the end user. There must be used a special liquid paint. Surface grinding is not necessary. The former corrosion protection will still exist.

NDV1200/1600/1800/2500/2600

The doors to the MV- and LV-rooms are fitted with each 3 hinges.

They have metal-swing lever locks, prepared for fitting standard profile cylinders with 45° or 90° lock-in angle. The profile cylinders are protected with weather hoods.

Similar swing lever locks are used for the plug-in shutters.

– The cylinders itself are not part of our standard supply! –

The door to the MV-room is fitted with a 4 times multiple security lock.

The doors can be latched either in left or right position.

This can be done even on site. Opening angle 90° and 135° .

Degree of protection

MV- and LV-Compartment IP 54D

Transformer compartment IP 43D

The substation, Type NDV1200 up to 2600 may be transported and lifted completely equipped.

The station is lifted via the base pan on the lifting lugs (refer to technical documentation, “lifting”).

For road transport, note the loading guidelines.

All fitted elements are electrically connected and earthed at a central earth star point in the LV- compartment.

All parts under voltage are shock prove covered (degree of protection IK10).

MV and LV compartment may be fitted with lights, switched by door switches.

Spare NH-Fuses may be stored with in the LV-compartment-door.

NDV1200/1600/1800/2500/2600

5. Equipment possibilities

MV-Switchgear:

The installation of MV-switchgears is possible on both operating sides of the compact substations. A combination of following switchgears can be chosen:

- Siemens, 8DJ20-8DH10, 24kV, 3-5 fields, height 1400 mm,
- Ormazabal (F&G) , GA 3-5 fields, height 1400 mm,
- Driescher, GISELA
- Driescher Moosburg , M3007, 36kV
- Ormazabal, CGM4SE , 36 kV, height 1400 mm , depth 1200 mm , width 1700 mm
- Areva, FBX, FBE, up to 36 kV, height 1400mm,depth 880mm, width up to 1460 mm

**MV-CT room for max. 3 CT's and 3 PT's max. 24 kV.
SF6- insulated – MV – Circuit breaker 12/24kV 630A.**



NDV1200/1600/1800/2500/2600

Transformer:

total dimensions of transformer room:

length 1980 mm,
width between 1200 to 1400 mm,
height 1900 mm (1600kVA) and 2200 mm (2500kVA)

for transformers up to 1600 kVA, 2000 kVA, 2500 kVA;
also installation of 2 transformers 630 kVA possible;
cast resin transformers up to 800 kVA

Connection between transformer and MV-switchboard with ready-to-fit cable, tested 50kV 1Min.

Connections to the LV-side are made load dependant, using high flexible, 3kV isolated cable.

Initialling or changing the transformers

When installing or replacing the transformer, all connections to the MV-switchboard and the LV-panel must be cut from power and earthed. The transformer is lifted out of the top of the station.

Use the following procedure:

- Remove the roof:
- Open the plug- shutters as entry in the transformer compartment and loosen the roof fixture screws (red marked) placed in the upper corner of the transformer compartment.
Lift the roof upside.
- Adjust the transport I-rails spacing on the base pan to match the transformer-undercarriage.
- Roll in the transformer and connect.
- Replace the roof and fix.

NDV1200/1600/1800/2500/2600

LV module:

LV-equipment depending on customers request!
LV-power factor compensation up to 300 kvar



6. Earth appliance

The central earth bar is situated in the LV-cabinet. The soil earth lead or deep soil earth are directly connected to the central earth bar. In this way, all housing parts and the base pan are directly connected to the main earth.

NDV1200/1600/1800/2500/2600

7. Transport, placing and mounting

The NDV1200 up to 2600 is manufactured ready for connection and fully tested.
For transport, placing and mounting refer to technical documentation.

Resulting terrain height and surface water must be considered when determining the excavation depth.

The excavation pit must have a strong floor bearing. Floor unevenness must be compensated with a levelled sand bed.
In case difficult floor conditions are encountered, a lean-concrete substructure or concrete thresholds are recommended.

The station is placed on site by using the adequate lifting gear.
The NDV1200 up to 2600 may be lifted and put in place completely equipped.
The lifting gear is fitted to the 4 lifting lugs on the base unit (see lifting plan).

Cable connection

MV-Side: Remove covers on the Base pan and lower covers of the switchgear.

LV-Side: Remove covers of the base pan and the floor panel.

All terminals are now accessible to the front for insertion and connection of cables.

After connecting all cables, all housing parts are replaced in reverse order.

Damages of the coating due to transport, lifting and mounting have to be repaired immediately.

NDV1200/1600/1800/2500/2600

8. Dimensions and weights

NDV1200

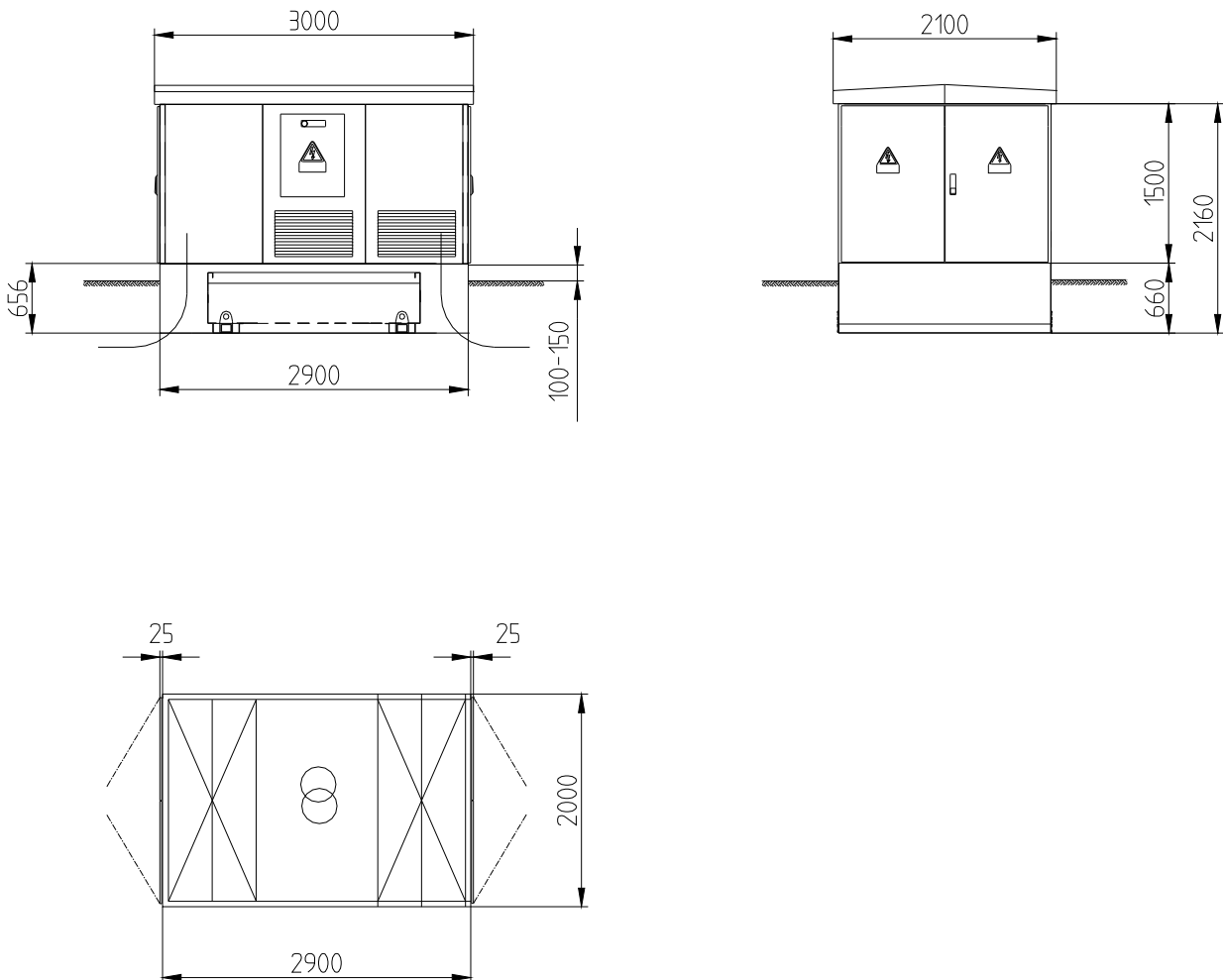

required space

set up area : 6,30 m²

area with opened doors : 10,30 m²

weights

housing alone : 1400 kg

total weight : 6000 kg (appr. value with transformer 1250 kVA and equipment)

NDV1200/1600/1800/2500/2600

NDV1600

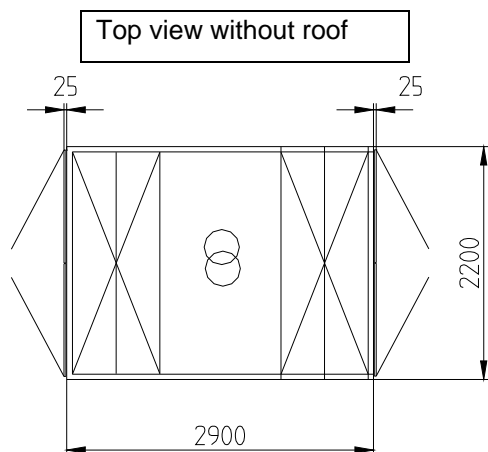
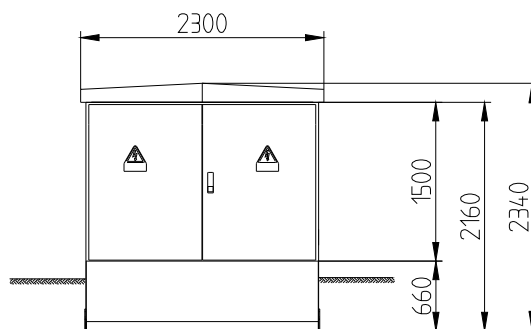
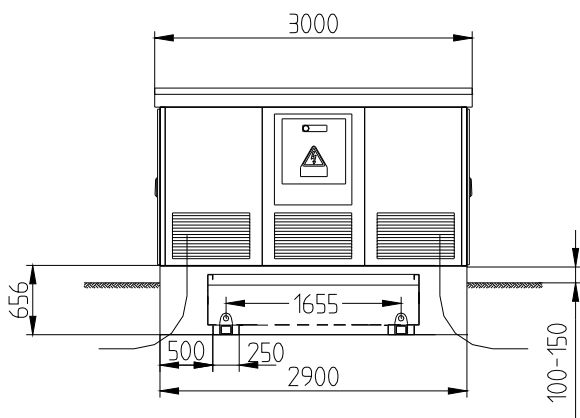

required space

set up area : 6,38 m²

area with opened doors : 10,60 m²

weights

housing alone : 1500 kg

total weight : 6500 kg (appr. value with transformer 1600 kVA and equipment)

NDV1200/1600/1800/2500/2600

NDV 2500

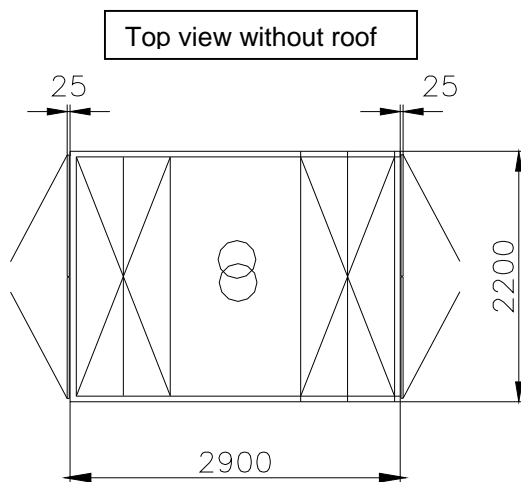
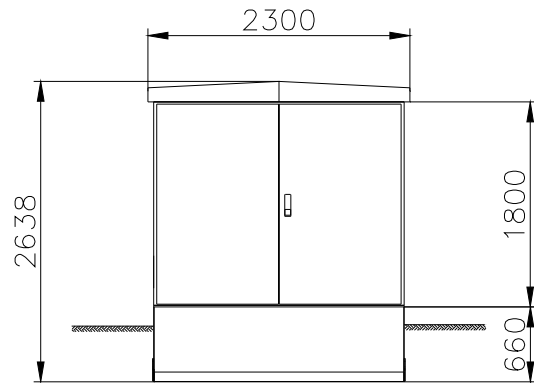
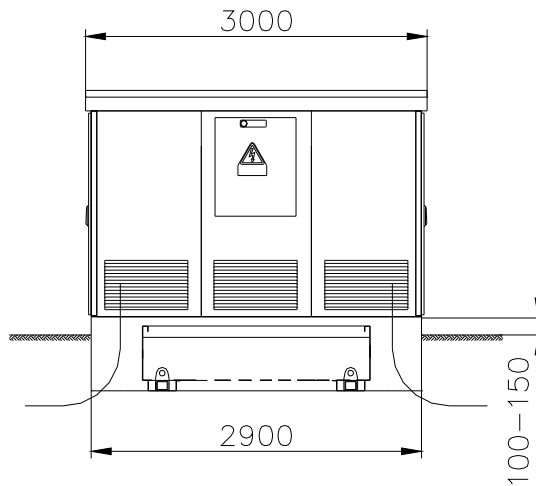

required space

set up area : 6,38 m²

area with opened doors : 10,60 m²

weights

housing alone : 1500 kg

total weight : 8500 kg (appr. value with transformer 2500 kVA and equipment)

NDV1200/1600/1800/2500/2600

NDV 1800

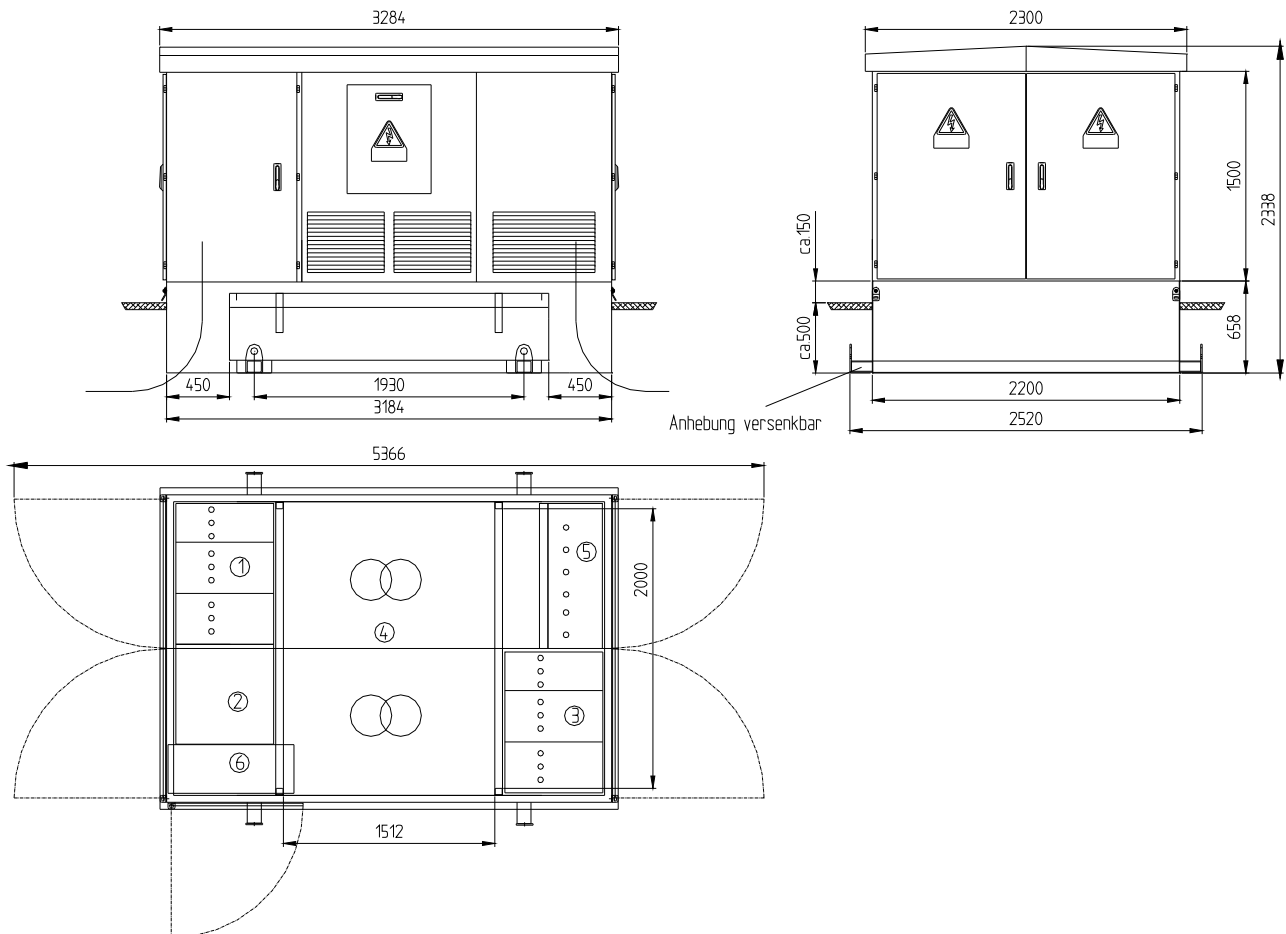

required space

set up area : 8 m²

area with opened doors : 13,50 m²

weights

housing alone : 1600 kg

total weight : 8500 kg (appr. value with transformer 2500 kVA and equipment)

NDV1200/1600/1800/2500/2600

NDV 2600

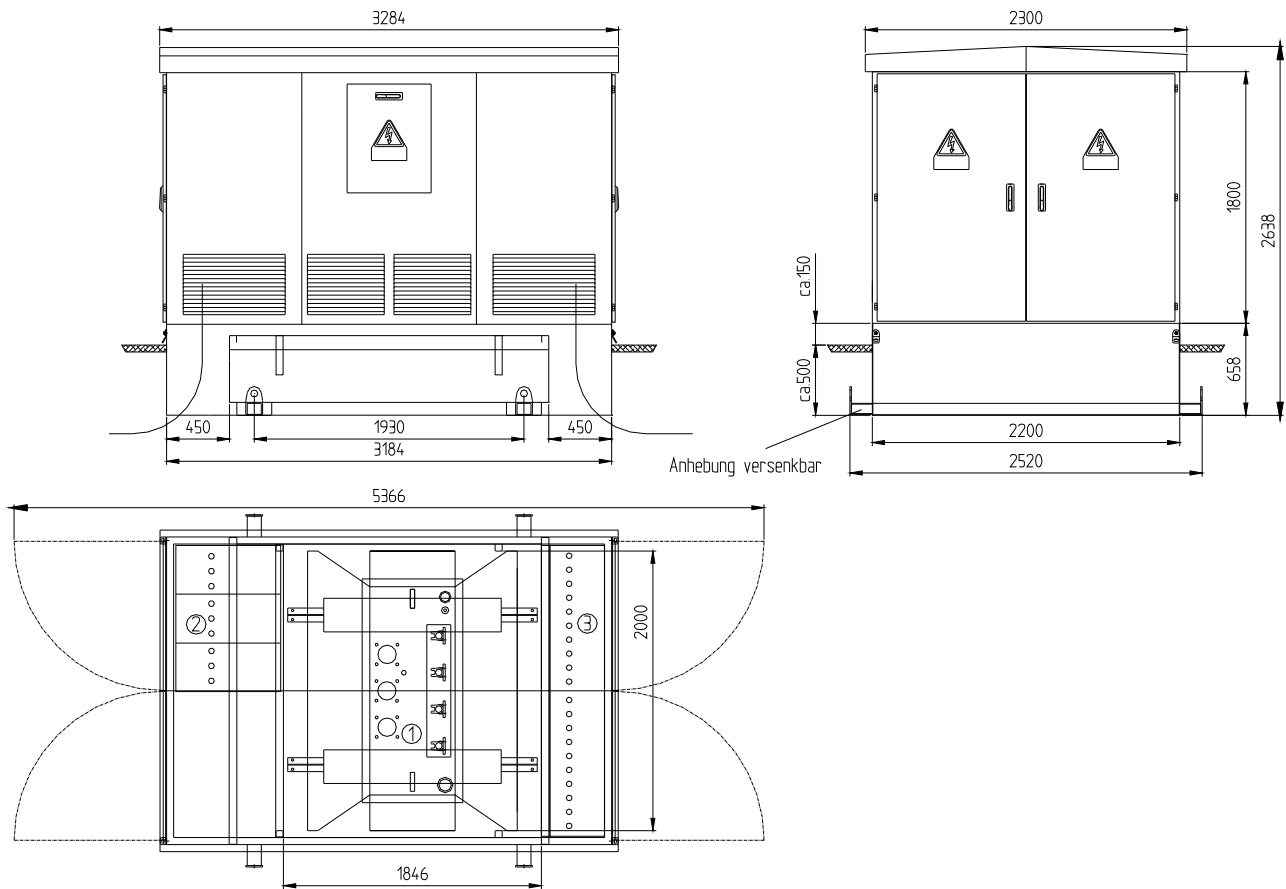

required space

set up area : 8 m²

area with opened doors : 13,50 m²

weights

housing alone : 1700 kg

total weight : 8700 kg (appr. value with transformer 2500 kVA and equipment)

NDV1200/1600/1800/2500/2600

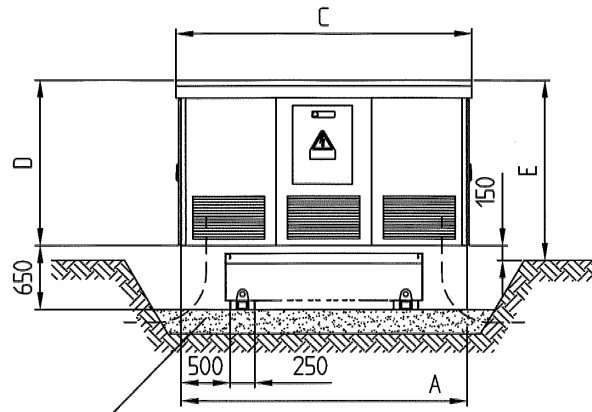

1) Thickness of concrete-floor-plate about 200mm
Ground bearing = 65 kN/m² up to 90 kN/m²

Dimensions in mm

	A	B	C	D	E	F	G	H
NDV1200	2900	2000	3000	1680	1830	4200	2945	1545
NDV1600	2900	2200	3000	1680	1830	4200	3145	1745
NDV1800	3184	2200	3284	1680	1830	4484	3145	1745
NDV2500	2900	2200	3000	1980	2130	4200	3145	1745
NDV2600	3184	2200	3284	1980	2130	4484	3145	1745

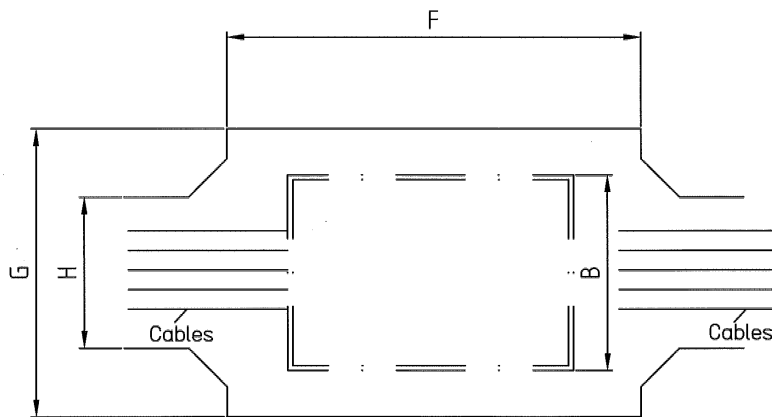

Subject to technical changes !

Allgemeintoleranzen						Maßstab	1:50	Gewicht (kg)
Oberfläche ISO 1302	Zerspanen ISO 2768-C	Biegen DIN 6935	Stanzen DIN 6930-m	Schweißen DIN 8570-B	Bewertung EN 25817-C	Werkstoff	Bauteil	
						Datum	Name	
						Bearb.	05.05.08 Meuleman	
						Gepr.		
						Norm		
Versand						Benennung		
A 791						Site excavation drawing		
A 751						NDV1200/1600/1800/2500/2600		
A 721						Zeich.-Nr.		Index
						0152M09		0
Verteiler						A.-Nr.		Ers.
Index	Änderung	Datum	Name	Urheberschutz nach DIN 34				A 4

NDV1200/1600/1800/2500/2600

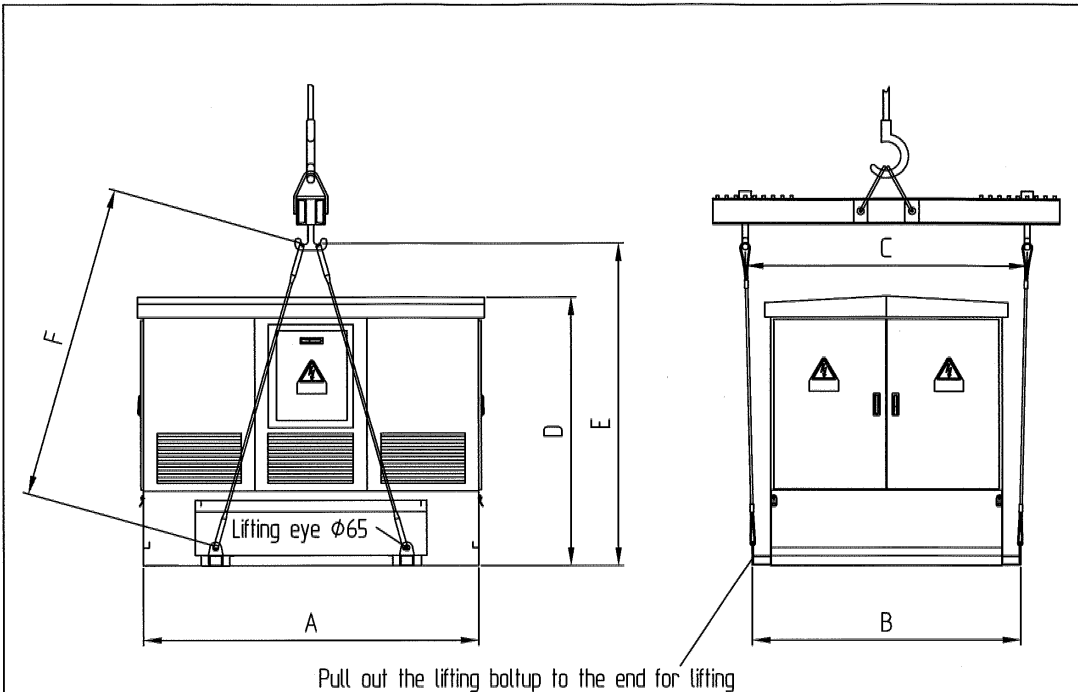

Dimensions in mm

	A	B	C	D	E	F
NDV1200	2900	2320	2400	2330	2800	ca. 2800
NDV1600	2900	2520	2600	2330	2800	ca. 2800
NDV1800	3184	2520	2600	2330	2800	ca. 2800
NDV2500	2900	2520	2600	2630	3100	ca. 3100
NDV2600	3184	2520	2600	2630	3100	ca. 3100

Subject to technical changes !

Allgemeintoleranzen						Maßstab	1:50	Gewicht (kg) bis	7000
Oberfläche	Zerspanen	Biegen	Stanzan	Schweißen	Bewertung	Werkstoff		Bauteil	
ISO 1302	ISO 2768-C	DIN 6935	DIN 6930-m	DIN 8570-B	EN 25817-C				
						Datum	Name		Benennung
						Bearb.	07.05.08		
						Gepr.	Meul		
						Norm			
						Lifting Plan			
						NDV1200/1600/1800/2500/2600			
Versand							Zeich.-Nr.	Index	
A 791							0152M12.	0	
A 751								4	
Verteiler	Index	Änderung	Datum	Name	Urheberschutz nach DIN 34	A.-Nr.	Ers.:		

NDV1200/1600/1800/2500/2600

Dimensions in mm

	A	B	C
NDV1200	3000	2100	2368
NDV1600	3000	2300	2368
NDV1800	3284	2300	2368
NDV2500	3000	2300	2668
NDV2600	3284	2300	2668

Weight up to 7000 kg

Forwarding Plan
NDV1200/1600/1800/2500/2600

Zähl-Nr. 0152M17
Index 0

Verfahren Index: A 791
Verfahren: A 791

Attention: Forwarding of substation only with airoperated suspended trucks
Transport in accordance with VDI 2700-2702